



苏州富加林自动化科技有限公司

SUZHOU FUJIALIN AUTOMATION EQUIPMENT & TECHNOLOGY CO., LTD.

企业宗旨：

创新是根本，质量是生命，
务实是宗旨，效益是目标

Purpose of the enterprise:

Innovation is the fundamental, Quality is everything,
Practical is the aim, Benefit is the goal

■ 公司简介 Company Profile

苏州富加林自动化科技有限公司坐落于苏州昆山市高新技术开发区，占地面积5000多平米，生产厂房3500多平米，是一家专业从事非标自动化设备、自动化生产线、工装夹具、机器人运用集成等研发制造为一体的高新技术创新企业，本公司可根据客户各种需求提供研发设计、加工、制造、售后等一体化服务。主要经营的领域有：机械、电子、电器、汽车、医疗等等。

苏州富加林自动化科技有限公司将会以不断科学创新，持续的研发设计与制造为基础，打破现有的劳动密集型产业生产效率较低的生产方式为目的，不断创新改造提升各领域的生产效率与品质，为进一步降低各企业生产成本而不懈努力。

Suzhou Fujialin Automation Technology Co., Ltd. is located in Kunshan High-tech Development Zone, Suzhou. Industrial Park in North Kunshan and cover with 5000 square meters and 3500 square meters production workshop. Fujialin Tech is a High-tech company specialized in non-standard Automatic Machine, Automatic Production Line, Fixtures, Autowelding, all kinds of robots and other similar machines in Automatic field. Our products can used almost in every field, such as Autoindustry, Electronic industry, machine industry, cosmetic industry, medical industry and so on.

Fujialin tech is devolving insell to transform the current labor intensive situation and decline the producing costs by using its advanced R&D capability ,creative lean production technology and impeccable service.

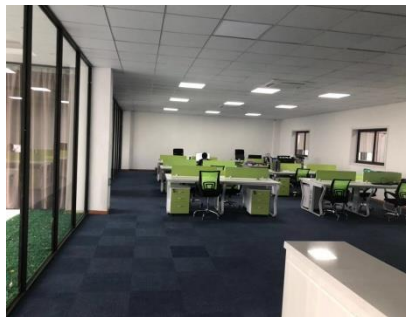

生产资质Productions

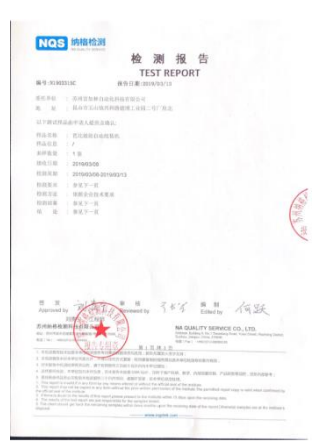
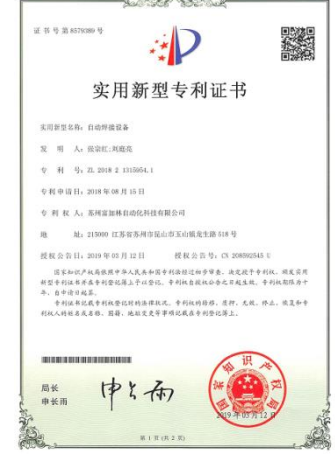
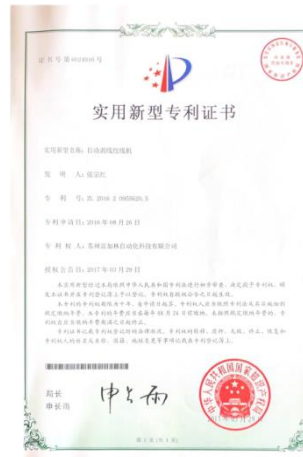

■ 主营业务 Main business

- 汽车
- 低压电气
- 航空航天
- 线路板
- 其他

3C及消费电子

发动机系统：机
油泵电子泵等生
产设备

线路板行业

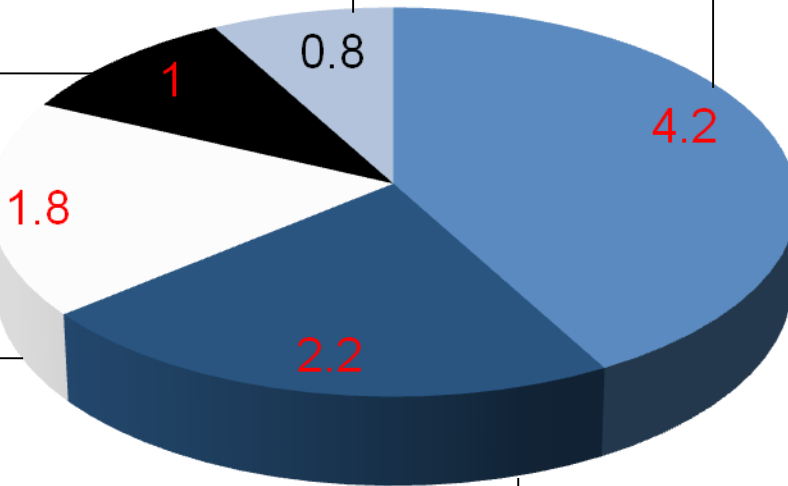

航空航天卫星电
源系统生产设备



工业自动化低压
电气生产线

■ 人力配置 Manpower allocation

公司有在职员工54人，管理及销售人员11人，研发团队22人

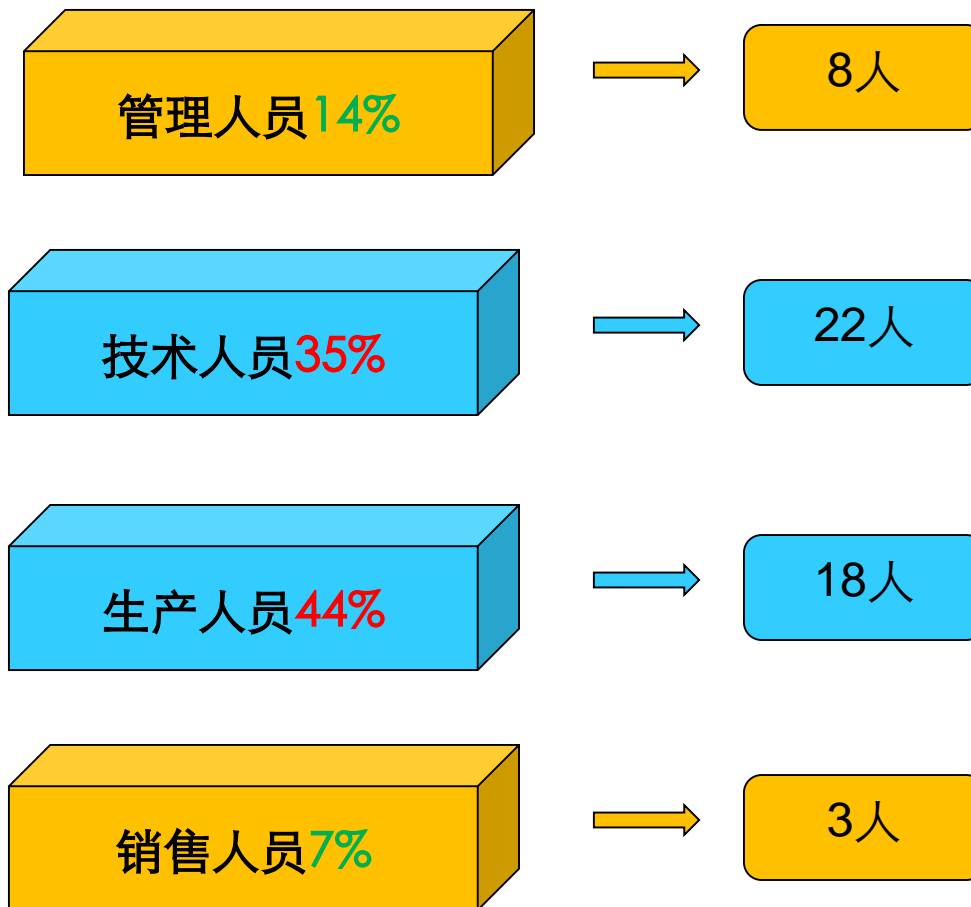

■ 公司主要客户Key account



Coroplast



中国航天科技集团公司
China Aerospace Science and Technology Corporation



LEAR
CORPORATION



CEIC 中国电科



KEBODA[®]
Creating Value, Sharing Progress



Schneider
Electric



MAGNA



SL 圣龙集团
SHENGLONG GROUP

■ 生产线展示 Production Line Display

■ 汽车类



汽车机油泵装配与检测生产线

Assembly and Inspection Production Line of Automotive Oil Pump

功能：自动进料，泄漏检测、组装油封、组装泵盖、性能测试、总成测试、自动打螺丝，数据追溯等

效率：3 件/分钟

Functions: automatic feeding, leakage detection, assembly of oil seals, assembly of pump caps, performance testing, assembly testing, automatic screwing, data traceability, etc.

Efficiency: 3 pieces per minute



■ 生产线展示 Production Line Display

■ 汽车类



汽车电机装配与检测生产线

Automotive Motor assembly & testing line

功能：自动进料，自动装转子、自动装电机端盖、自动打螺丝、总成性能测试、动平衡测试、数据追溯等

效率：2 件/分钟

Functions: automatic feeding, automatic loading of rotors, automatic loading of motor end caps, automatic screwing, assembly performance testing, dynamic balance testing, data traceability, etc.

Efficiency: 2 pieces per minute

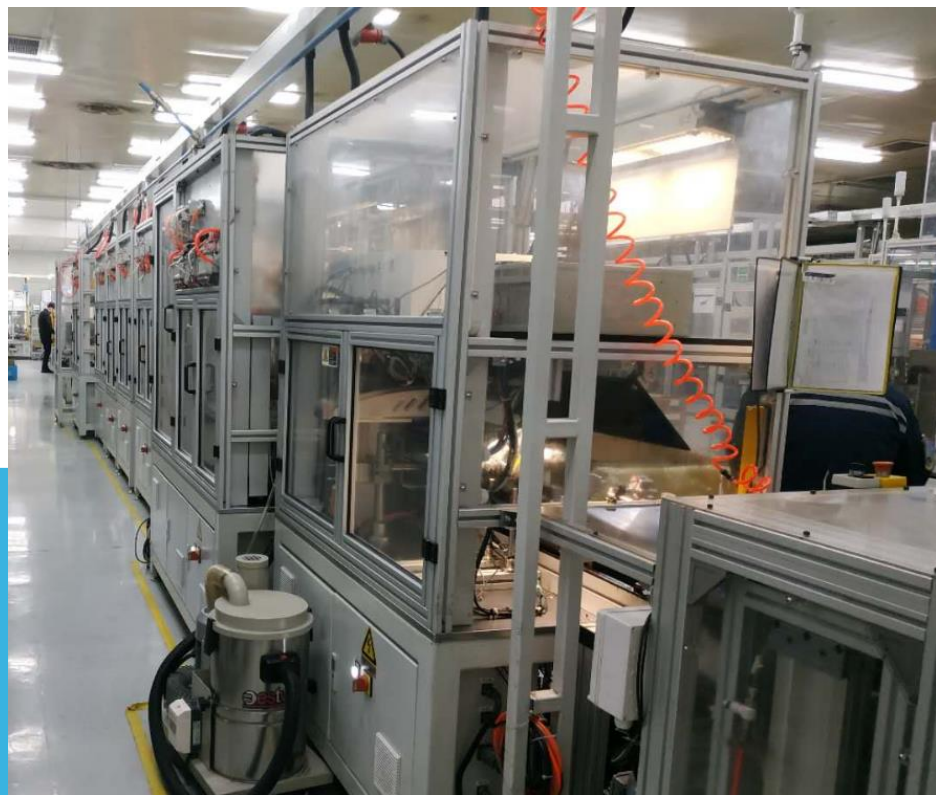

■ 生产线展示 Production Line Display

■ 汽车类



电动汽车冷却系统装配与检测生产线 Electric Vehicle Cooling System Assembly and Inspection Production Line

功能：泄漏测试、压水管、装密封盖、打螺丝、数据追溯等
效率：2 件/分钟

Functions: Leakage test, pressure pipe, sealing cover, screwing, data traceability, etc.
Efficiency: 2 pieces per minute



■低压电气类 The category of low voltage electrical



漏电开关自动检测设备

Electric Leakage Switch automatic detect machine

功能：全自动进料、抓取，高压检测、漏电检测、不良排除，自动卸料
效率：20 件/分钟

Function: Full automatic feeding, snatch at, high voltage detect, electric leakage detect, Elimination of defective products, automatic discharging

Efficiency: 20 pcs/min



titant最终测试设备

Titant final detect machine

功能：高低压检测，不良排除，自动卸料等功能
效率：15 件/分钟

Function: High&low voltage detect, Elimination of defective products, automatic discharging

Efficiency: 15 pcs/min

按钮触点开关组装检测设备

Button contact switch assembly detect machine



功能：自动进料，高低压检测、漏电检测、行程检测，压力检测，自动松螺钉，不良排除，自动卸料，双面激光打标
效率：20 件/分钟

Function: Automatic feeding, high&low voltage detect、electric leakage detect、traveling detect、pressure detect Self loosening screw、Elimination of defective products、automatic discharging、Double side laser marking
Efficiency: 20 pcs/min

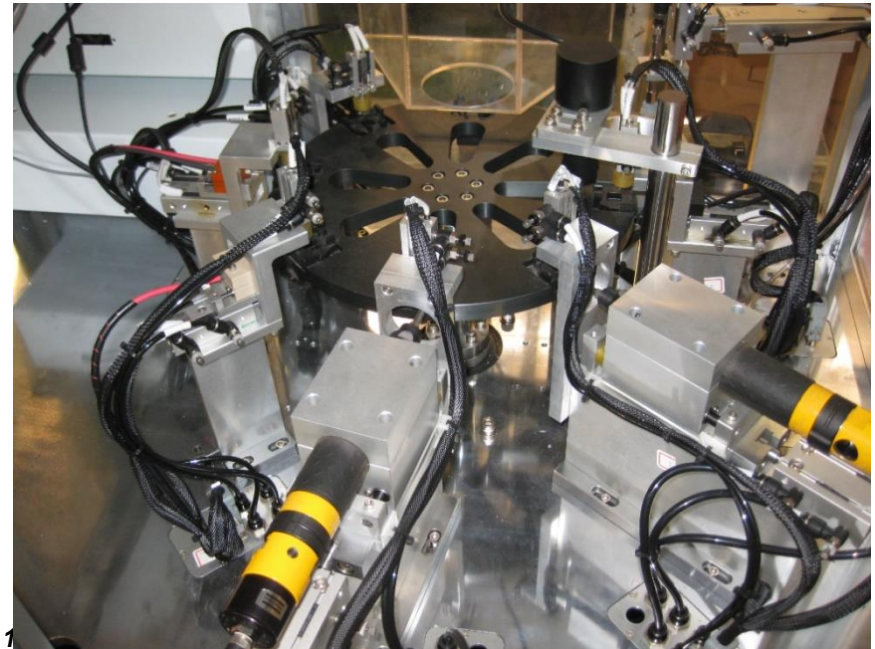

■ 内部展示 Inside show

■ 连接器类 Connector

汽车连接器压端子测试设备

The terminals of Automobile connector
detect machine



功能：全自动进料，压端子，切carry，导通检测，耐压测试，不良排除，自动卸料

效率：30 件/分钟

Function: Full automatic feeding, press terminals, cut carry, breakover detect, withstand voltage detect, Elimination of defective products, automatic discharging

Efficiency: 30 pcs /min

SMT产品组装密封盖载带包装设备

SMT product- seal cover assmebling
and packaging machine

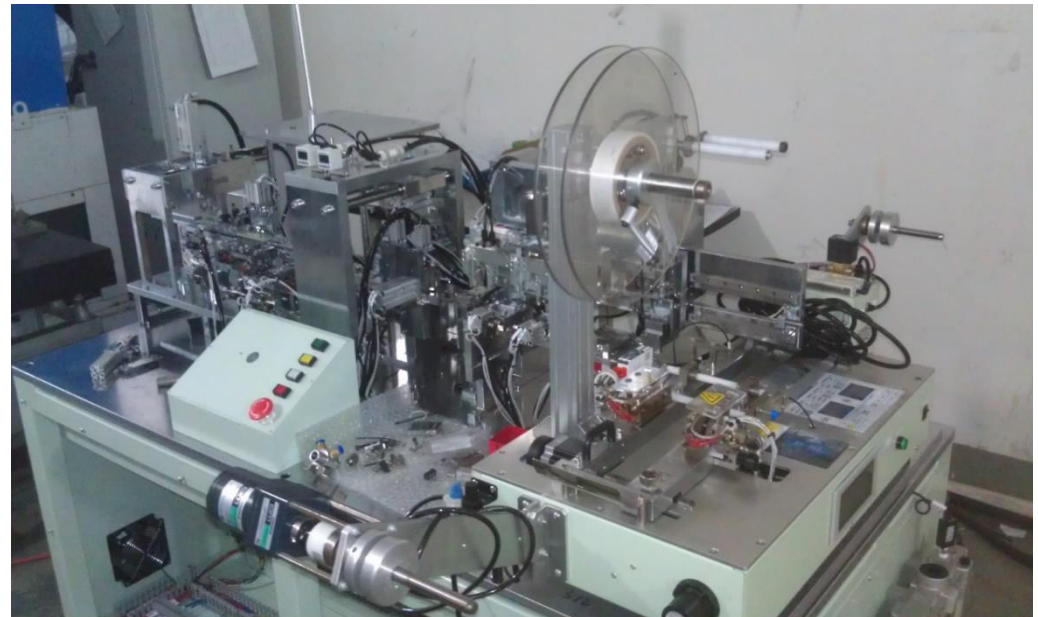

功能：全自动进料，自动除尘，自动组装密封盖，自动检测，自动包装

效率：40 件/分钟

Function: Full automatic feeding, automatically remove dust, automatic assmeble seal cover, automatic detect, automatic packaging
efficiency: 40 pcs/min

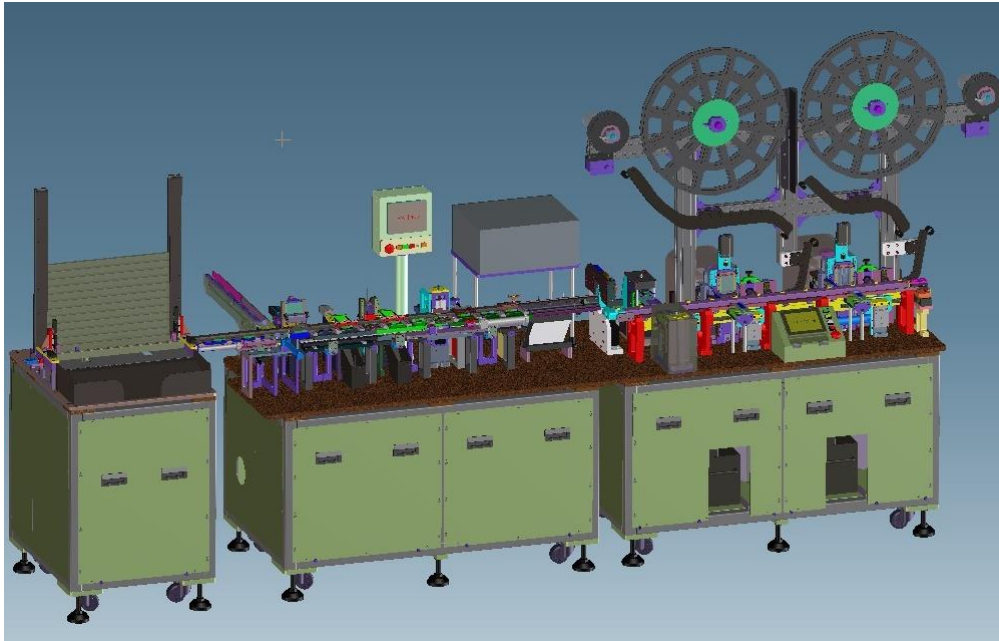

SMT产品折弯凸轮插针机
SMT product bend and insert pin cams machine

功能：SMT产品端子折弯、插入、导通耐压测试及包装
效率：30 件/分钟

Function:SMT terminal bending, inserting, unchoke withstand
voltage testing and packing.

Efficiency:30 pcs/min

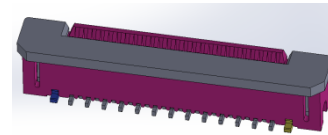
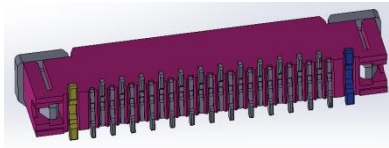

连接器自动插针检测包装机
Connector pin automatic
inserting, resting and packing

功能：汽车连接器的端子裁切、分pin插入、压入，
导通耐压、正位度检测和自动托盘包装
效率：30件/分钟

Function:Automobile connector terminal
cutting, pin inserting, pressing, position
testing and packing

Efficiency:30 pcs/min

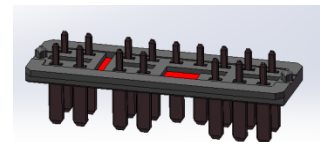
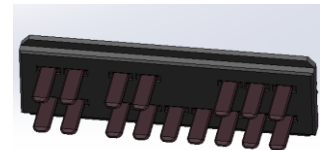
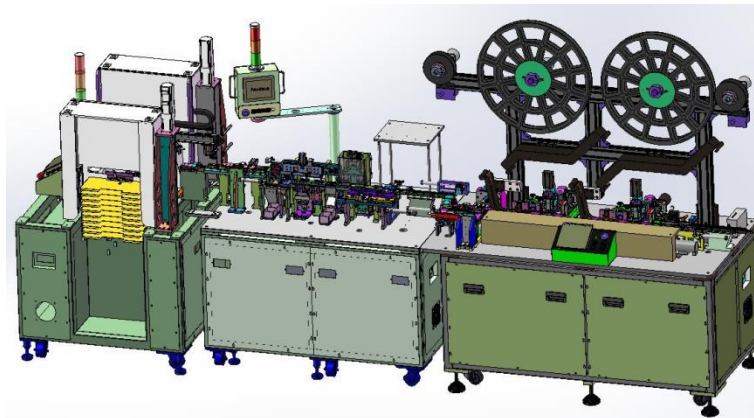

■ 案例展示 Sample project

■ 线束线缆类 Cable



自动剥线绞线机

Wire automatic stripping and twisting machine

功能：兼容50mm至650mm，2芯线/3芯线/4芯线剥皮绞线
Function: compatible 50mm to 650mm, the wire with 2/3/4 cores can be stripping and twisting

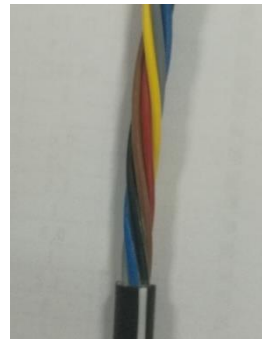

ABS自动装皮套机

ABS automatic assemble leather cover machine

功能：设备自动将皮套装到连接器上，可兼容线材和管材2种规格
Function: leather cover can be automatic insert into the connector ,compatible wires and tubings



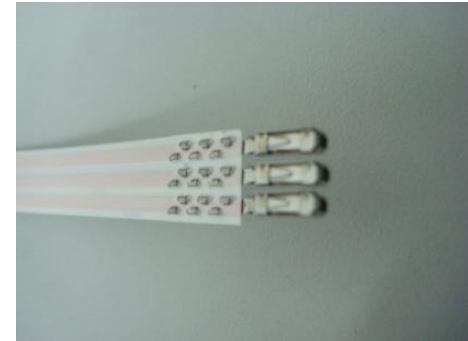

电缆自动铆合影像系统检测

Automatic riveting and image system testing

功能：汽车传输线的自动铆接，检测，不良排出

效率：20 件/分钟

Function: Automatic riveting, testing and rejects
ejecting for Autos

Efficiency: 20 pcs/min



电源插头自动组装设备

Attaching plug automatic assemble machine

功能：设备自动裁切线缆，剥皮，分线，装导电片，铆接，自动搬运至注塑机

效率：20 件/分钟

Function: Automaitic crop ,stripping, separating,assemble conducting strip, riveting,automatic carry to the injection molding machine

Efficiency: 20 pcs/min



■ 案例展示 Sample project

■ 生产线类 Assembly line

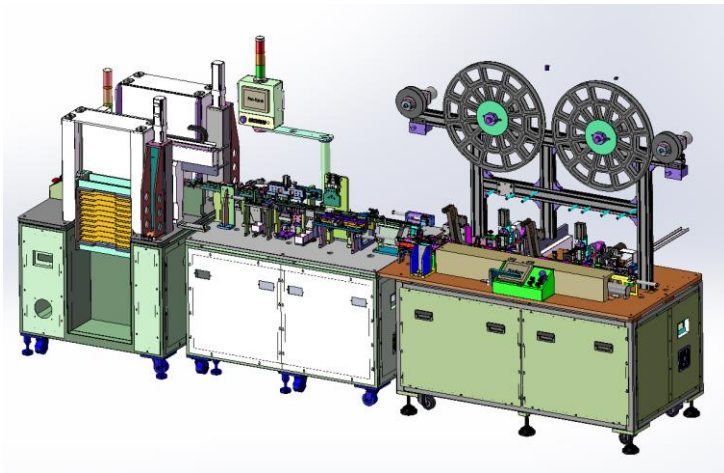

连接器自动插针检测包装生产线
Automatic line for connector pin inserting, resting and packing



变速箱装配生产线
Transmission assembly line



灵敏度检测生产线
Sensibility testing producing line

功能：接触器的失效和灵敏度模拟测试
效率：10 件/分钟
Function: Automatic testing for connector
sensibility and invalidation
Efficiency: 10 pcs/min



安全气囊装配测试生产线
Airbags assembling and testing line

■ 案例展示 Sample project

■ 机器人运用 The management of robots

端子五金件自动注塑

Terminals automatic inject machine

功能：四种五金件自动送料，自动裁切，机器人抓取，机械人注塑上下料，CCD自动对位，CCD自动检测，四轴机器人上下料堆垛
效率：6 模/ 分钟

Function: Four kind of hardware automatic feeding, automatic crop, snatch at by robot, injecting and feeding by robot, CCD automatic find the position, CCD automatic detect, feeding and stacking by 4 axis robot

Efficiency: 6 mold cavity/min

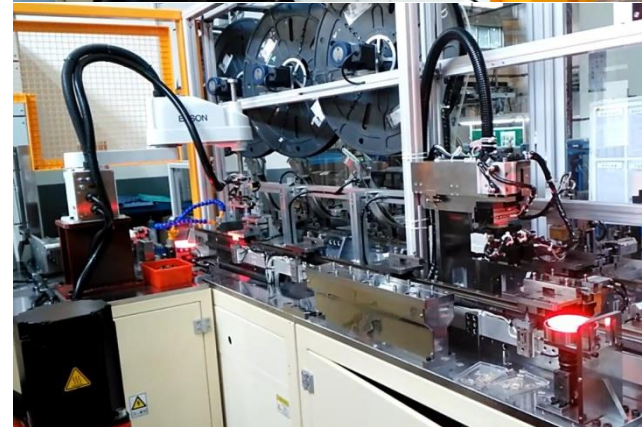
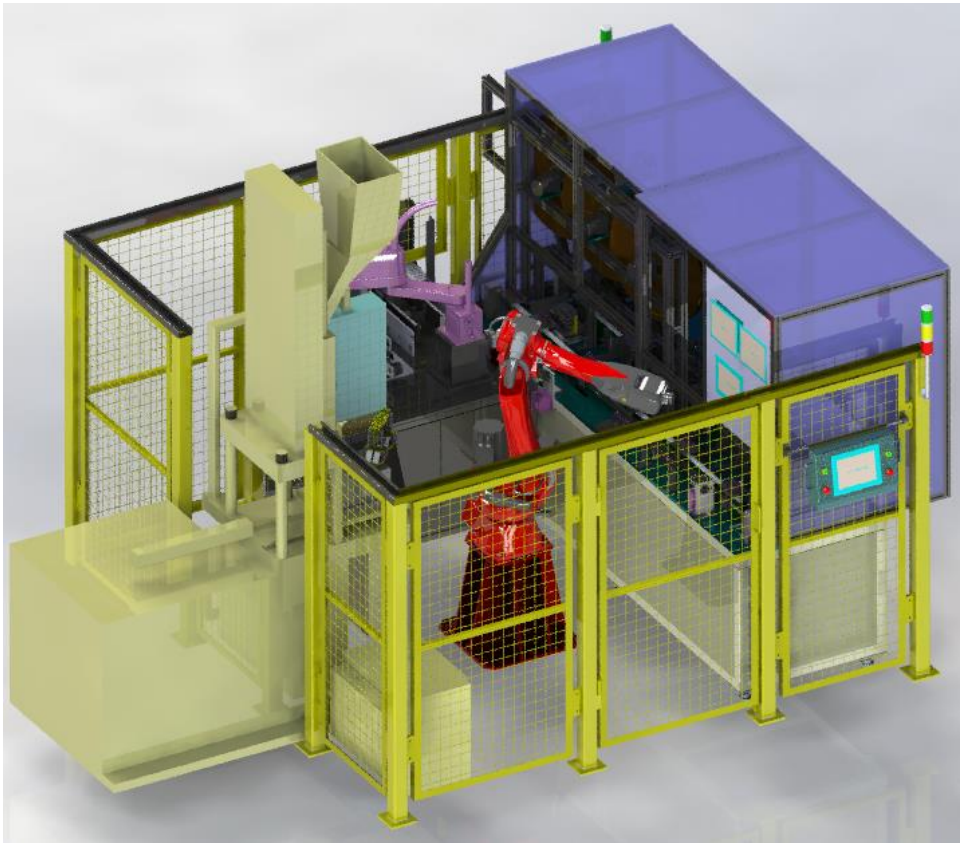

■ 真空设备运用 Application of vacuum equipment

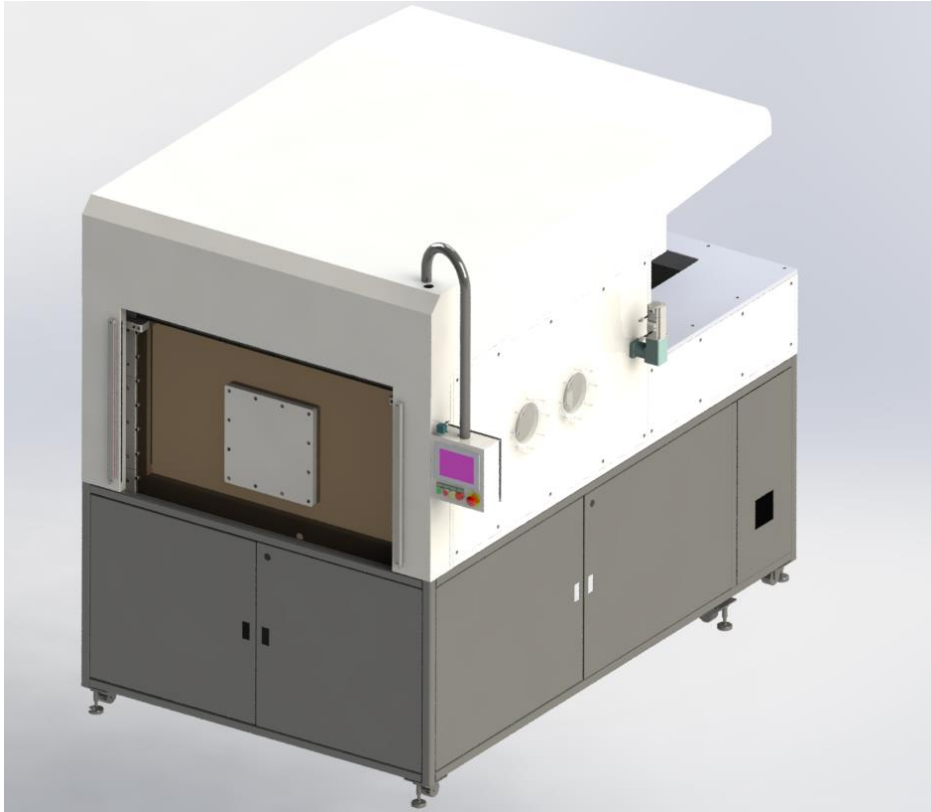

电路板树脂真空塞孔设备

Vacuum Pore-mending Equipment for Resin of PCB

功能：线路板行业多层板树脂油墨补孔，高真空环境下，进行油墨补孔，真空度可达到-100KPa。

效率：1片/分钟

Functions: In the PCB industry, multi-layer board resin ink filling hole, under high vacuum environment, ink filling hole, vacuum degree can reach - 100KPa.

Efficiency: 1 tablet per minute



砷化镓太阳能电池自动焊接设备
Solar cell automatic soldering machine

功能：自动完成电池片及银互连片的上下料，
CCD自动对位，错位自动校正，碎片CCD自动检测，
来料自动码垛

效率：1 件/分钟

Function: Automatic complete the cell's
feeding, CCD automatic find the
position, correct the wrong position, CCD
automatic detect chip, automatic feeding
and stacking

Efficiency: 1 pcs/min

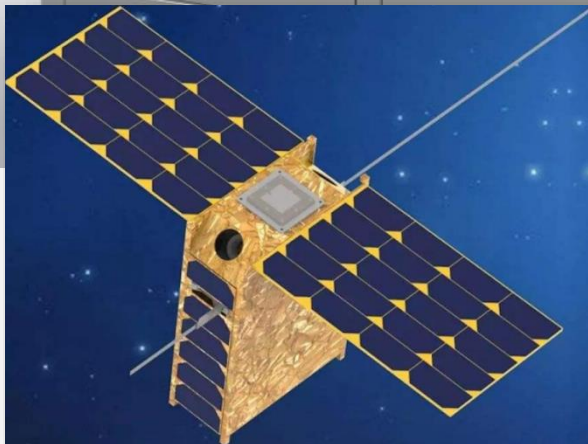
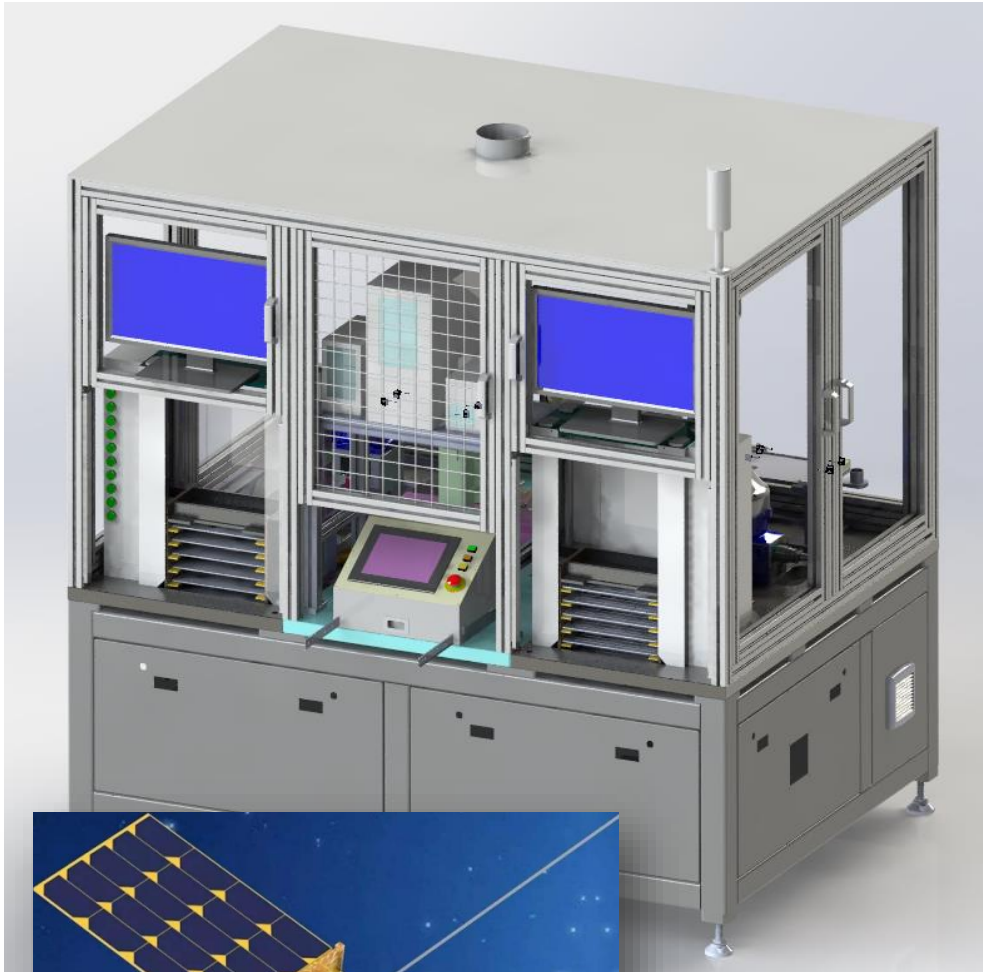

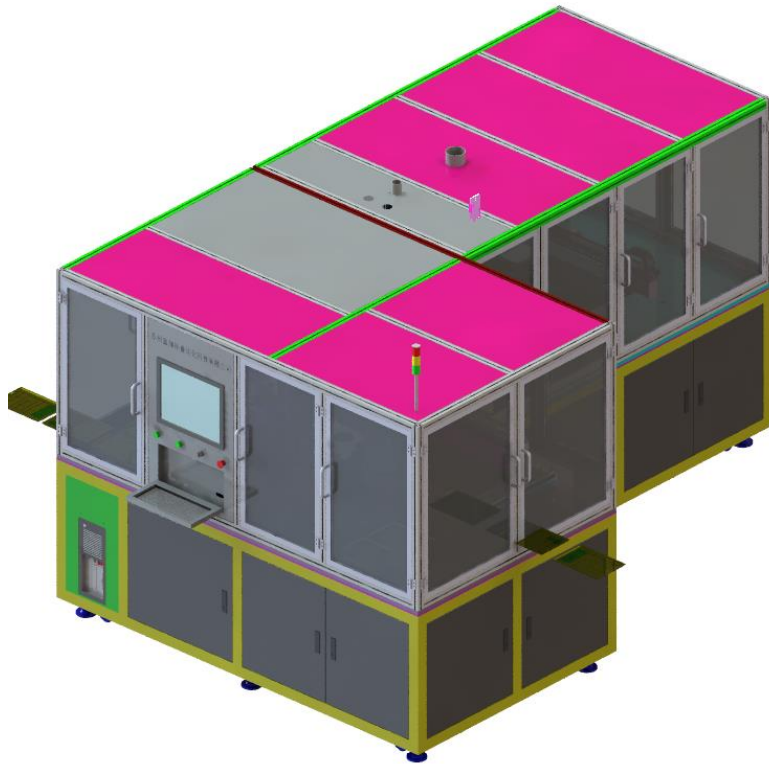

砷化镓太阳能电池自动贴玻璃盖片设备
Solar cell automatic glass cover equipment

功能：自动完成电池片及玻璃盖片的上下料，CCD自动对位，错位自动校正，碎片CCD自动检测，来料自动码垛
效率：1 件/分钟

Functions: automatic loading and unloading of batteries and glass cover, automatic alignment of CCD, automatic correction of dislocation, automatic detection of debris CCD, automatic stacking of incoming materials
Efficiency: 1 pcs/min

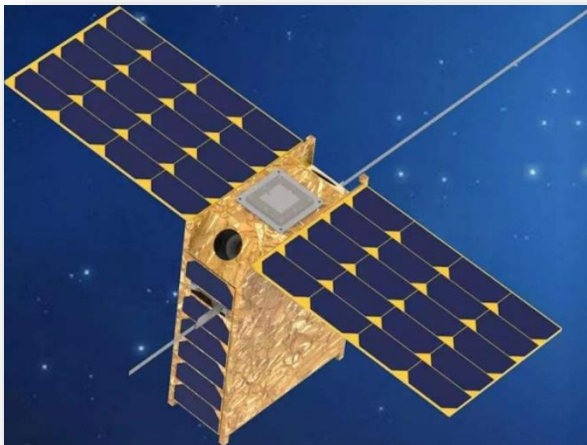
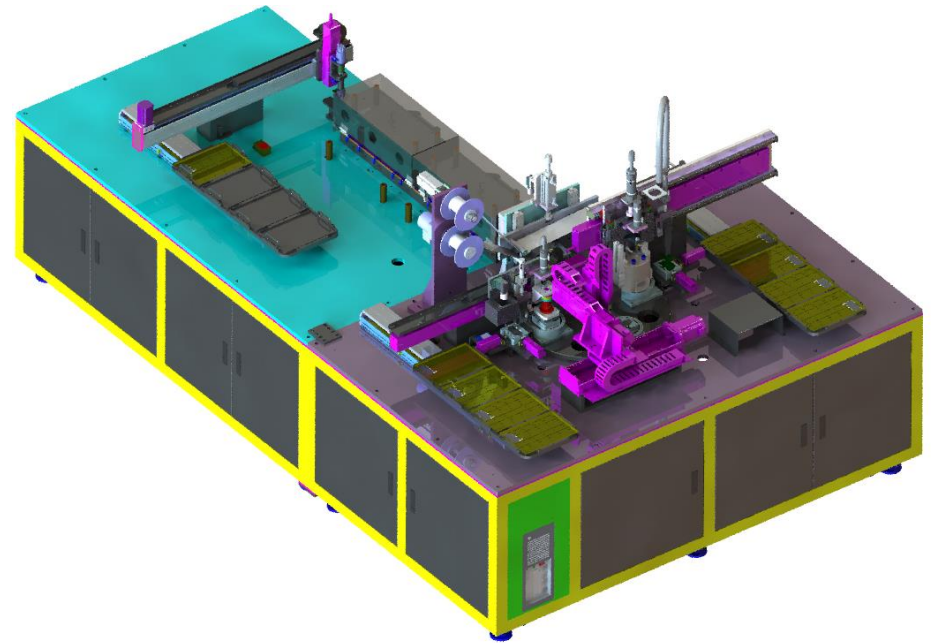

砷化镓太阳能电池半自动焊接设备

GaAs solar cell semi-automatic welding equipment

功能：自动完成电池片及银互连片的上下料，CCD自动对位，错位自动校正

效率：1 件/分钟

Function: automatic loading and unloading of battery and silver interconnect, CCD automatic alignment, automatic correction of dislocation
Efficiency: 1 pcs/min

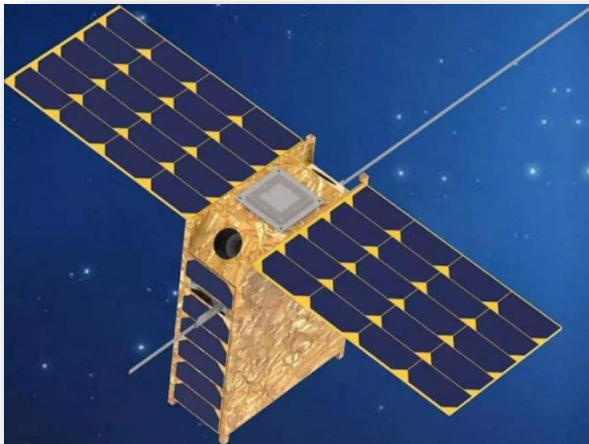
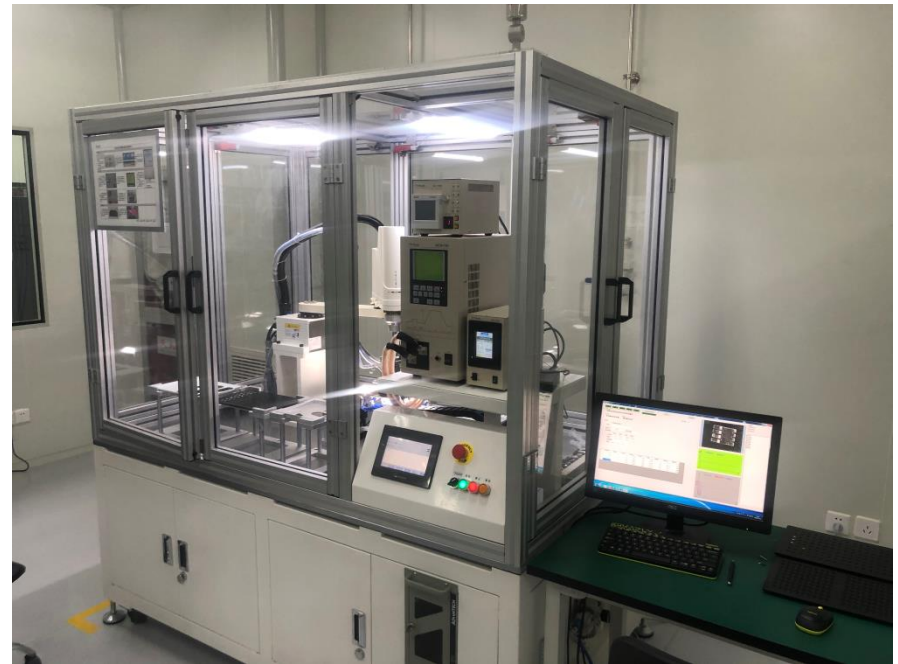
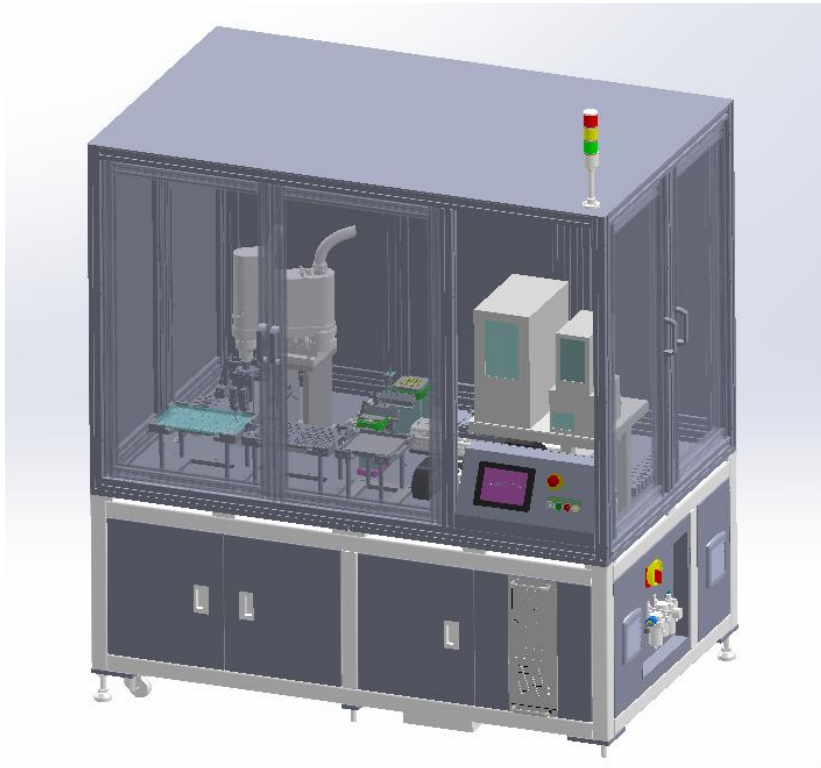

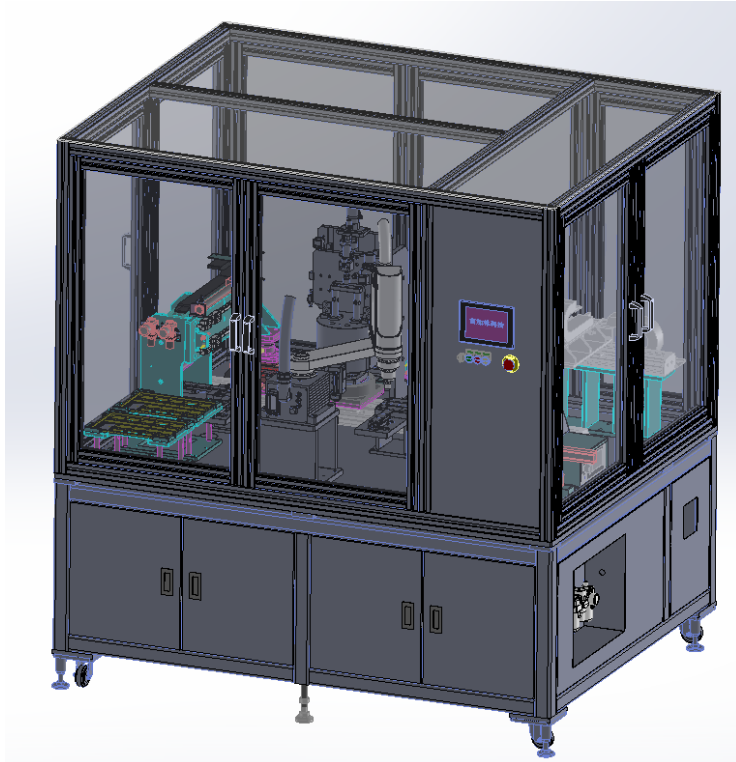

砷化镓太阳能电池半自动贴玻璃盖片设备
Solar cell automatic glass cover equipment

功能：自动完成电池片及玻璃盖片的上下料，自动对位，错位自动校正，来料自动码垛

效率：1 件/分钟

Function: automatic loading and unloading of battery and glass cover, automatic alignment, automatic correction of dislocation, automatic stacking of incoming materials

Efficiency: 1 pcs/min



砷化镓太阳能电池焊接设备

GaAs solar cell welding equipment

功能：人工完成电池片及银互连片的上下料，CCD自动对位，错位自动校正

效率：2分钟/件

Function: manual loading and unloading of battery and silver interconnect, CCD automatic alignment, dislocation automatic correction
dislocationEfficiency:2 min/pcs

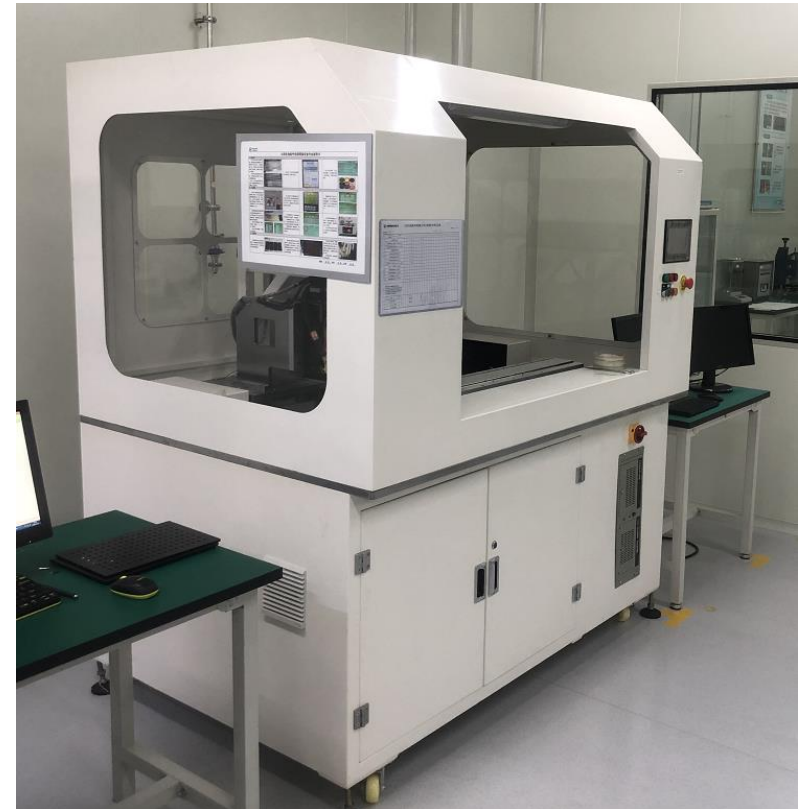
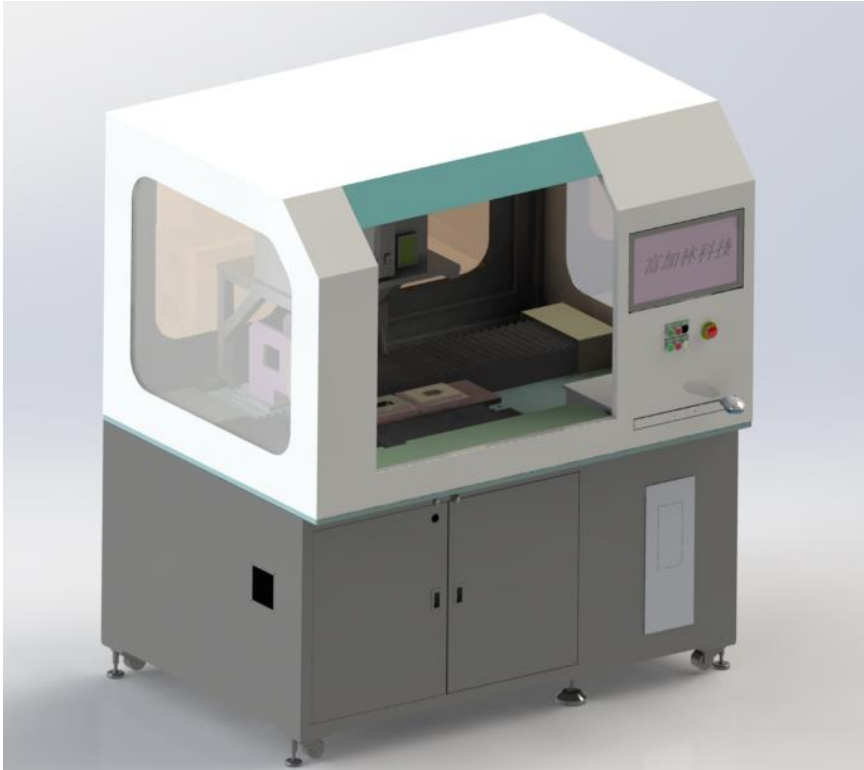



砷化镓太阳能电池半自动贴玻璃盖片设备
Solar cell automatic glass cover equipment

功能：自动完成电池片及玻璃盖片的上下料，自动对位，错位自动校正，来料自动码垛

效率：3分钟/件

Function: automatic loading and unloading of battery and glass cover, automatic alignment, automatic correction of dislocation, automatic stacking of incoming materials

Efficiency: 3 min/pcs



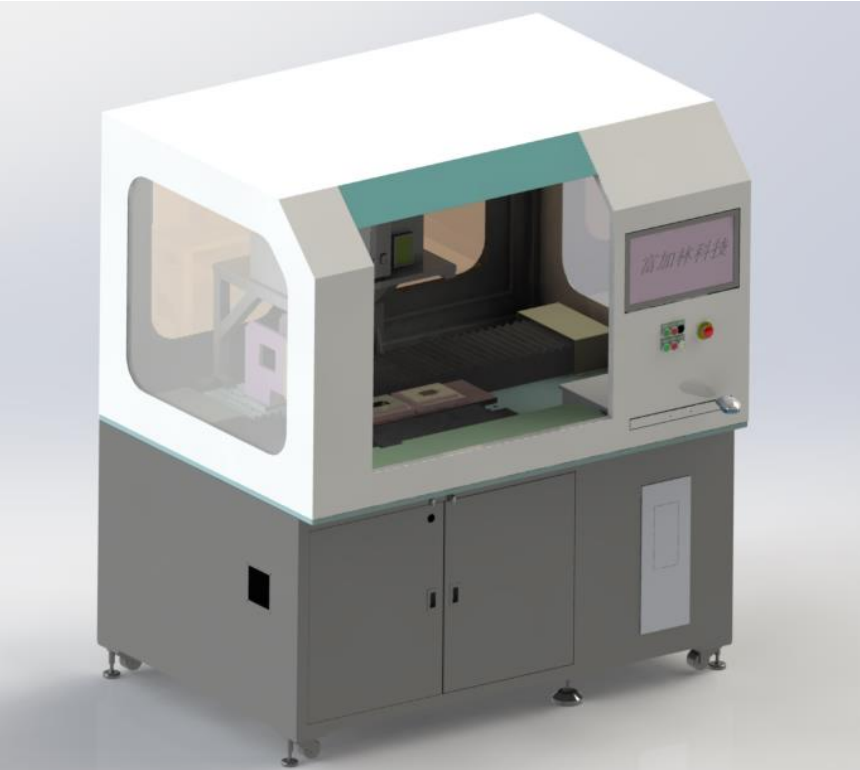

砷化镓太阳能电池自动串焊设备
Solar cell automatic tandem welding equipment

功能：人工按照需求，将电池片放入焊接设备，CCD自动对位，自动串联焊接

效率：1片/分钟

Function: Manually according to the requirements, put the battery into welding equipment, CCD automatic alignment, automatic series welding
Efficiency: 1 tablet per minute

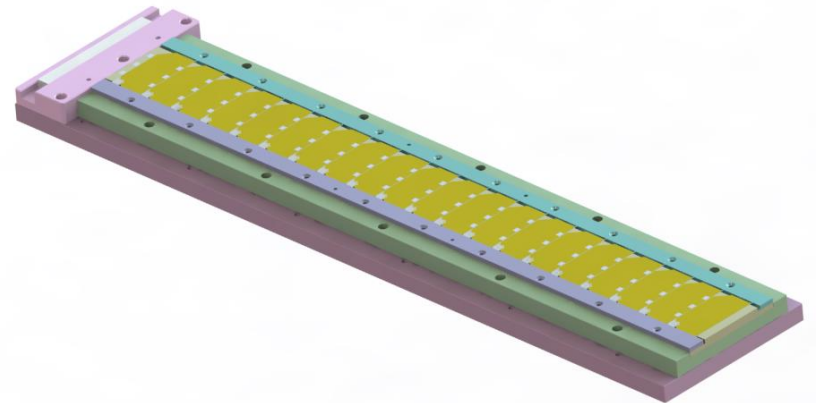

■ 案例展示 Sample project

■ 夹治具类 Fixtures



贴标治具
Marking fixture



压螺母治具
Nut pressing fixture

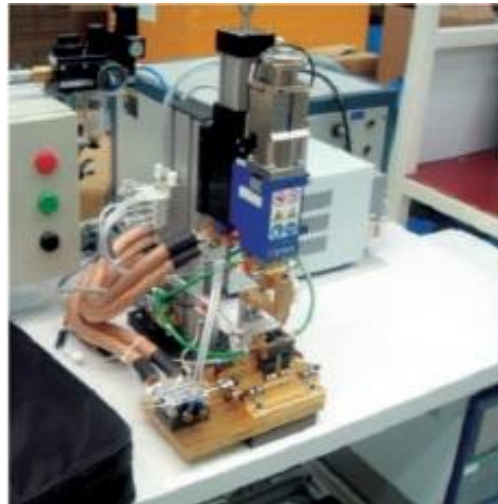

电阻焊治具
Resistance welding fixture



热熔治具
Hot-melting fixture

谢谢！

Thank you !

- * 感谢您的观看！
- * 我们成长来自您的信任和支持。
- * 我们将尽一切努力，为您带来有效专业化的自动化设备。

- * Many thanks for review.
- * Our growth comes from you trust and support.
- * We will try our best to provide you the most efficient and professional factory automation solutions.

- * <http://www.szfujialin.com>
- * [Tel:+86 18912670537](tel:+8618912670537) +86 13912678906

